

PVDF

产品目录

product catalogue



沧州华祥塑业有限公司

地址：河北省沧州市盐山县

电话：13903170785 0317-5301871

网址：<http://www.czhsy.com>

| 目录 | 页码 |
|--------|-------|
| 管 道 | 3 |
| 承插焊接管件 | 4-12 |
| 对焊管件 | 13-23 |
| 球 阀 | 24 |
| 法兰系列 | 25-28 |

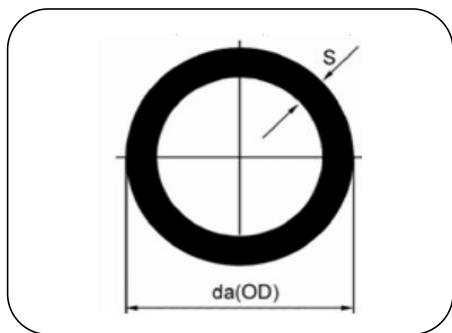

- PVDF 管 本色
- 挤出成型
- 4 米或 5 米
- PVDF natural
- extruded moulded
- 4m or 5m

| 尺寸 Dimension | 公称壁厚, S, mm | | |
|-----------------|-------------|-------|-------|
| | 公称压力, PN | | |
| | 风管 LINER | 10 | 16 |
| | 标准尺寸比 | | |
| | SDR17.6 | SDR33 | SDR21 |
| 20 | - | - | 1.9 |
| 25 | - | - | 1.9 |
| 32 | - | - | 2.4 |
| 40 | - | - | 2.4 |
| 50 | - | - | 3.0 |
| 63 | - | 2.0 | 3.0 |
| 75 | - | 2.3 | 3.6 |
| 90 | - | 2.8 | 4.3 |
| 110 | 3.0 | 3.4 | 5.3 |
| 125 | 3.0 | 3.9 | 6.0 |
| 140 | 3.0 | 4.3 | 6.7 |
| 160 | 3.0 | 4.9 | 7.7 |
| 180 | 3.0 | 5.5 | 8.6 |
| 200 | 3.0 | 6.2 | 9.6 |
| 225 | 3.0 | 6.9 | 10.8 |
| 250 | 3.0 | 7.7 | 11.9 |
| 280 | 3.5 | 8.6 | 13.4 |
| 315 | 4.0 | 9.7 | - |
| 355 | 4.0 | 10.8 | - |
| 400 | 5.0 | 12.2 | - |

承插焊接管件

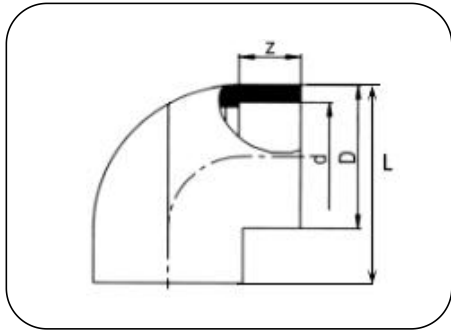

- 90° 弯头 I
- 注塑成型
- 承插焊接
- PVDF 本色
- Elbow 90° I
- Injection moulded
- Socket welding
- PVDF natural

| 尺寸 Dimension | 公称压力 PN | d mm | D mm | L mm | z mm |
|-----------------|------------|---------|---------|---------|---------|
| 20 | 16 | 19.2 | 28 | 44 | 14 |
| 25 | 16 | 24.2 | 34 | 50 | 18 |
| 32 | 16 | 31.1 | 42 | 61 | 18 |
| 40 | 16 | 39.0 | 51 | 71 | 20 |
| 50 | 16 | 48.9 | 63 | 83 | 23 |
| 63 | 16 | 61.9 | 79 | 100 | 25 |
| 75 | 16 | 73.7 | 91 | 114 | 33 |
| 90 | 16 | 88.6 | 110 | 140 | 36 |
| 110 | 16 | 108.4 | 130 | 160 | 43 |

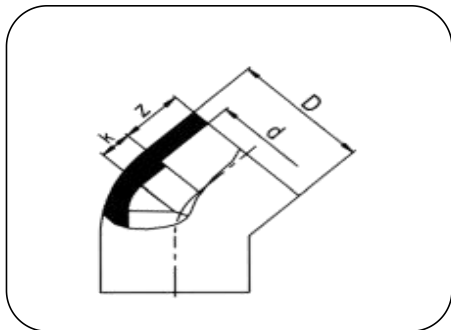

- 45° 弯头 I
- 注塑成型
- 承插焊接
- PVDF 本色
- Elbow 45° I
- Injection moulded
- Socket welding
- PVDF natural

| 尺寸 Dimension | 公称压力 PN | d mm | D mm | k mm | Z mm |
|-----------------|------------|---------|---------|---------|---------|
| 20 | 16 | 19.2 | 29 | 12 | 14 |
| 25 | 16 | 24.2 | 35 | 15 | 18 |
| 32 | 16 | 31.1 | 43 | 17 | 18 |
| 40 | 16 | 39.0 | 51 | 22 | 20 |
| 50 | 16 | 48.9 | 63 | 24 | 23 |
| 63 | 16 | 61.9 | 79 | 30 | 25 |
| 75 | 16 | 73.7 | 91 | 38 | 3 |
| 90 | 16 | 88.6 | 110 | 45 | 36 |
| 110 | 16 | 108.4 | 130 | 57 | 41 |

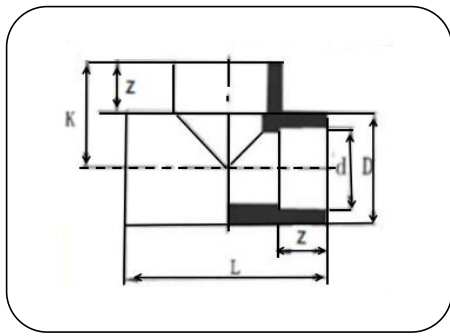

- 三通 I
- 注塑成型
- 承插焊接
- PVDF 本色
- Tee I
- Injection moulded
- Socket welding
- PVDF natural

| 尺寸 Dimension | 公称压力 PN | d mm | D mm | k mm | z mm | L mm |
|-----------------|------------|---------|---------|---------|---------|---------|
| 20 | 16 | 19.2 | 28 | 31 | 17 | 59 |
| 25 | 16 | 24.2 | 35 | 33 | 17 | 67 |
| 32 | 16 | 31.1 | 43 | 39 | 19 | 79 |
| 40 | 16 | 39.0 | 51 | 46 | 21 | 92 |
| 50 | 16 | 48.9 | 63 | 53 | 23 | 106 |
| 63 | 16 | 61.9 | 79 | 63 | 29 | 123 |
| 75 | 16 | 73.7 | 91 | 75 | 34 | 151 |
| 90 | 16 | 88.6 | 110 | 87 | 35 | 174 |
| 110 | 16 | 108.4 | 130 | 97 | 41 | 200 |

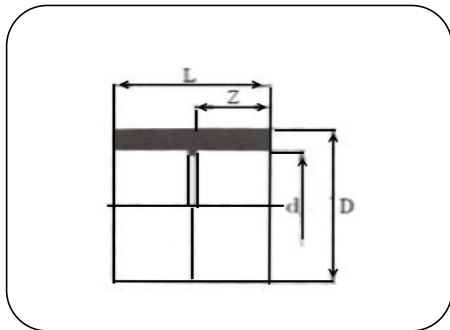

- 直接 I
- 注塑成型
- 承插焊接
- PVDF 本色
- Socket I
- Injection moulded
- Socket welding
- PVDF natural

| 尺寸 Dimension | 公称压力 PN | d mm | D mm | L mm | z mm |
|-----------------|------------|---------|---------|---------|---------|
| 20 | 16 | 19.2 | 29 | 35 | 15 |
| 25 | 16 | 24.2 | 35 | 39 | 17 |
| 32 | 16 | 31.1 | 42 | 42 | 19 |
| 40 | 16 | 39.0 | 52 | 47 | 20 |
| 50 | 16 | 48.9 | 63 | 51 | 23 |
| 63 | 16 | 61.9 | 80 | 60 | 27 |
| 75 | 16 | 73.7 | 90 | 69 | 31 |
| 90 | 16 | 88.6 | 112 | 72 | 36 |
| 110 | 16 | 108.4 | 130 | 90 | 42 |

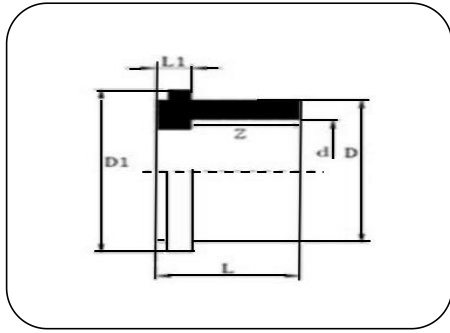

- 活接端 I
- 注塑成型
- 承插焊接
- PVDF 本色
- Union end I
- Injection moulded
- Socket welding
- PVDF natural

| 尺寸 Dimension | 公称压力 PN | d mm | D mm | D1 mm | L mm | L1 mm | z mm |
|-----------------|------------|---------|---------|----------|---------|----------|---------|
| 20 | 16 | 19.2 | 22 | 34 | 21 | 4 | 16 |
| 25 | 16 | 24.2 | 35 | 43 | 22 | 5 | 17 |
| 32 | 16 | 31.1 | 41 | 48 | 23 | 5 | 19 |
| 40 | 16 | 39.0 | 52 | 59 | 27 | 5 | 21 |
| 50 | 16 | 48.9 | 60 | 68 | 30 | 5 | 24 |
| 63 | 16 | 61.9 | 75 | 86 | 36 | 6 | 28 |

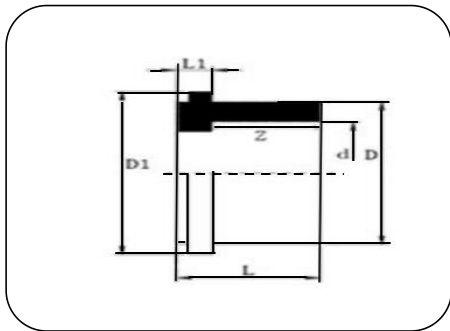

- 活接端 II
- 注塑成型
- 承插焊接
- PVDF 本色
- Union end II
- Injection moulded
- Socket welding
- PVDF natural

| 尺寸 Dimension | 公称压力 PN | d mm | D mm | D1 mm | L mm | L1 mm | Z mm |
|-----------------|------------|---------|---------|----------|---------|----------|---------|
| 20 | 10 | 19.2 | 27 | 30 | 19 | 5 | 15 |
| 25 | 10 | 24.2 | 36 | 39 | 21 | 5 | 18 |
| 32 | 10 | 31.1 | 41 | 45 | 23 | 6 | 19 |
| 40 | 10 | 39.0 | 52 | 56 | 25 | 6 | 22 |
| 50 | 10 | 48.9 | 58 | 62 | 28 | 7 | 24 |
| 63 | 10 | 61.9 | 73 | 78 | 32 | 7 | 29 |

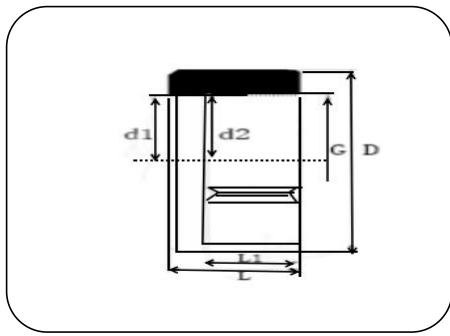

- 活接螺母 I
- G 螺纹
- 注塑成型
- 承插焊接
- PVDF 本色
- Union nut I
- G tread
- Injection moulded
- Socket welding
- PVDF natural

| 尺寸 Dimension | 公称压力 PN | D mm | d1 mm | d2 mm | L1 mm | L mm | G inch |
|-----------------|------------|---------|----------|----------|----------|---------|-----------|
| 20 | 16 | 46 | 28 | 38 | 18 | 24 | 1 1/4 |
| 25 | 16 | 57 | 36 | 45 | 18 | 25 | 1 1/2 |
| 32 | 16 | 68 | 42 | 50 | 23 | 29 | 1 3/4 |
| 40 | 16 | 80 | 54 | 62 | 23 | 30 | 2 1/4 |
| 50 | 16 | 91 | 62 | 74 | 26 | 34 | 2 3/4 |
| 63 | 16 | 110 | 76 | 93 | 31 | 39 | 3 1/2 |

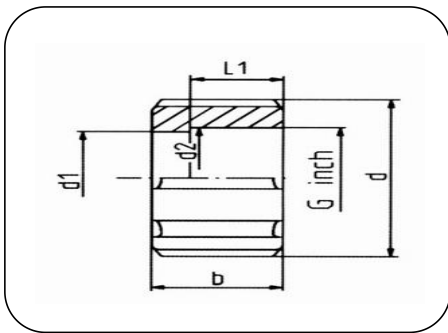

- 活接螺母 II
- G 螺纹
- 注塑成型
- 承插焊接
- PVDF 本色
- Union nut II
- G tread
- Injection moulded
- Socket welding
- PVDF natural

| 尺寸 Dimension | 公称压力 PN | D mm | d1 mm | d2 mm | L1 mm | b mm | G inch |
|-----------------|------------|---------|----------|----------|----------|---------|-----------|
| 20 | 10 | 42 | 22 | 30 | 17 | 22 | 1 |
| 25 | 10 | 53 | 32 | 39 | 18 | 24 | 1 1/4 |
| 32 | 10 | 61 | 38 | 45 | 19 | 26 | 1 1/2 |
| 40 | 10 | 72 | 48 | 57 | 22 | 28 | 2 |
| 50 | 10 | 82 | 56 | 62 | 25 | 33 | 2 1/4 |
| 63 | 10 | 100 | 70 | 78 | 27 | 35 | 2 3/4 |

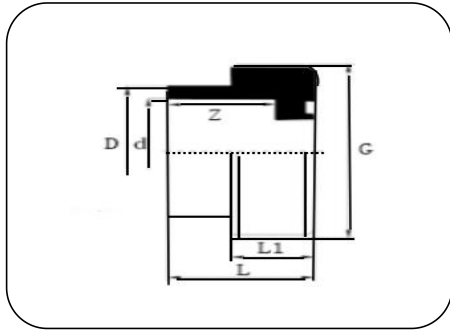

- 活接套筒 I
- G 螺纹
- 注塑成型
- 承插焊接
- PVDF 本色
- Union bush I
- G tread
- Injection moulded
- Socket welding
- PVDF natural

| 尺寸 Dimension | 公称压力 PN | d mm | D mm | L mm | L1 mm | z mm | G inch |
|-----------------|------------|---------|---------|---------|----------|---------|-----------|
| 20 | 16 | 19.2 | 22 | 23 | 13 | 17 | 1 1/4 |
| 25 | 16 | 24.2 | 35 | 27 | 15 | 21 | 1 1/2 |
| 32 | 16 | 31.1 | 41 | 30 | 18 | 21 | 1 3/4 |
| 40 | 16 | 39.0 | 52 | 30 | 18 | 24 | 2 1/4 |
| 50 | 16 | 48.9 | 60 | 36 | 19 | 24 | 2 3/4 |
| 63 | 16 | 61.9 | 75 | 42 | 23 | 29 | 3 1/2 |

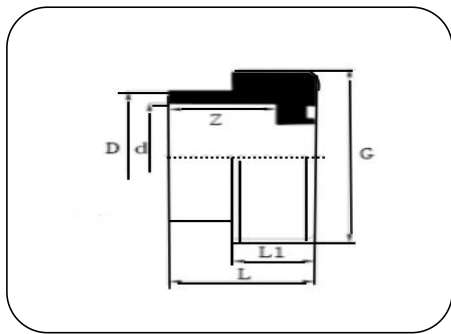

- 活接套筒 II
- G 螺纹
- 注塑成型
- 承插焊接
- PVDF 本色
- Union bush II
- G tread
- Injection moulded
- Socket welding
- PVDF natural

| 尺寸 Dimension | 公称压力 PN | d mm | D mm | L mm | L1 mm | Z mm | G inch |
|-----------------|------------|---------|---------|---------|----------|---------|-----------|
| 20 | 10 | 19.2 | 26 | 26 | 14 | 15 | 1 |
| 25 | 10 | 24.2 | 32 | 28 | 15 | 18 | 1 1/4 |
| 32 | 10 | 31.1 | 40 | 29 | 16 | 19 | 1 1/2 |
| 40 | 10 | 39.0 | 49 | 34 | 18 | 21 | 2 |
| 50 | 10 | 48.9 | 60 | 40 | 22 | 24 | 2 1/4 |
| 63 | 10 | 61.9 | 75 | 48 | 24 | 29 | 2 3/4 |

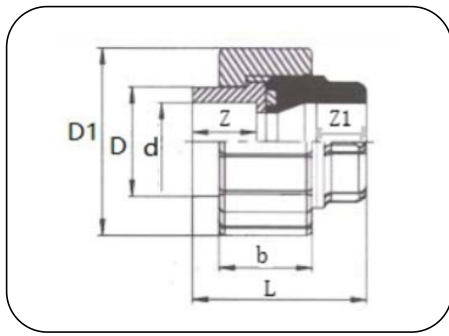

- 活接 I
- FPM-密封
- 注塑成型
- 承插焊接
- PVDF 本色
- Union Type I
- FPM-sealing
- Injection moulded
- Socket welding
- PVDF natural

| 尺寸 Dimension | 公称压力 PN | d mm | D mm | D1 mm | b mm | L mm | Z mm | Z1 mm |
|-----------------|------------|---------|---------|----------|---------|---------|---------|----------|
| 20 | 16 | 19.2 | 22 | 46 | 24 | 45 | 16 | 17 |
| 25 | 16 | 24.2 | 35 | 57 | 25 | 50 | 17 | 21 |
| 32 | 16 | 31.1 | 41 | 68 | 29 | 55 | 19 | 21 |
| 40 | 16 | 39.0 | 52 | 80 | 30 | 59 | 21 | 24 |
| 50 | 16 | 48.9 | 60 | 91 | 34 | 67 | 24 | 24 |
| 63 | 16 | 61.9 | 75 | 110 | 39 | 78 | 28 | 29 |

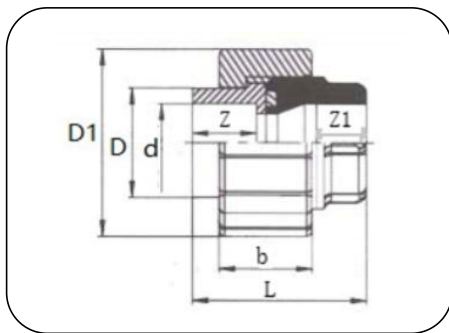

- 活接 II
- FPM-密封
- 注塑成型
- 承插焊接
- PVDF 本色
- Union Type II
- FPM-sealing
- Injection moulded
- Socket welding
- PVDF natural

| 尺寸 Dimension | 公称压力 PN | d mm | D mm | D1 mm | b mm | L mm | Z mm | Z1 mm |
|-----------------|------------|---------|---------|----------|---------|---------|---------|----------|
| 20 | 16 | 19.2 | 27 | 43 | 23 | 45 | 16 | 16 |
| 25 | 16 | 24.2 | 35 | 53 | 24 | 50 | 18 | 17 |
| 32 | 16 | 31.1 | 41 | 61 | 27 | 52 | 19 | 19 |
| 40 | 16 | 39.0 | 52 | 74 | 29 | 60 | 22 | 21 |
| 50 | 16 | 48.9 | 60 | 82 | 33 | 68 | 24 | 24 |
| 63 | 16 | 61.9 | 73 | 102 | 35 | 80 | 28 | 29 |

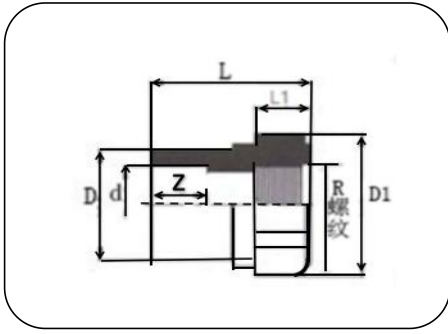

- 内螺纹管接头 I ● Adaptor Female Thread I
- 注塑成型或机加工 ● Injection moulded or Process molding
- 承插焊接 ● Socket welding
- PVDF 本色 ● PVDF natural

| 尺寸 Dimension | 公称压力 PN | d mm | D mm | L mm | L1 mm | D1 mm | Z mm | R inch |
|-----------------|------------|---------|---------|---------|----------|----------|---------|-----------|
| 20 | 16 | 19.2 | 30 | 44 | 16 | 32 | 15 | 1/2 |
| 25 | 16 | 24.2 | 35 | 50 | 18 | 40 | 17 | 3/4 |
| 32 | 16 | 31.1 | 43 | 56 | 20 | 45 | 18 | 1 |
| 40 | 16 | 39.0 | 51 | 62 | 24 | 54 | 20 | 1 1/4 |
| 50 | 16 | 48.9 | 63 | 67 | 26 | 69 | 23 | 1 1/2 |
| 63 | 16 | 61.9 | 79 | 73 | 29 | 83 | 28 | 2 |

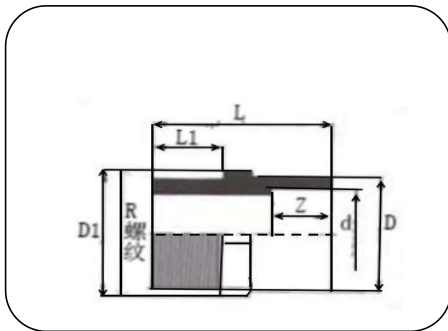

- 外螺纹管接头 I ● Adaptor Male Thread I
- 注塑成型或机加工 ● Injection moulded or Process molding
- 承插焊接 ● Socket welding
- PVDF 本色 ● PVDF natural

| 尺寸 Dimension | 公称压力 PN | d mm | D mm | L mm | L1 mm | D1 mm | Z mm | R inch |
|-----------------|------------|---------|---------|---------|----------|----------|---------|-----------|
| 20 | 16 | 19.2 | 25 | 48 | 16 | 21 | 17 | 1/2 |
| 25 | 16 | 24.2 | 32 | 61 | 23 | 34 | 18 | 3/4 |
| 32 | 16 | 31.1 | 40 | 66 | 27 | 40 | 21 | 1 |
| 40 | 16 | 39.0 | 51 | 74 | 28 | 51 | 28 | 1 1/4 |
| 50 | 16 | 48.9 | 63 | 76 | 30 | 70 | 22 | 1 1/2 |
| 63 | 16 | 61.9 | 80 | 82 | 32 | 83 | 27 | 2 |

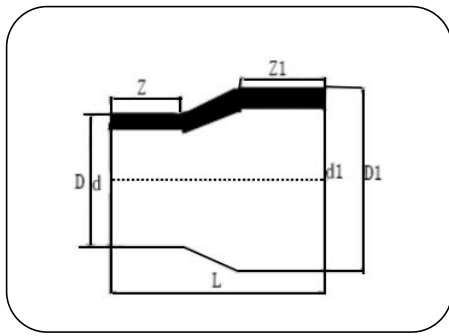

- 同心变径 I
- 注塑成型
- 承插焊接
- PVDF 本色
- Reducer concentric I
- Injection moulded
- Socket welding
- PVDF natural

| 尺寸 Dimension | 公称压力 PN | d mm | D mm | d1 mm | D1 mm | L mm | Z mm | Z1 mm |
|-----------------|------------|---------|---------|----------|----------|---------|---------|----------|
| 25/20 | 16 | 19.2 | 29 | 24.2 | 35 | 40 | 14 | 18 |
| 32/20 | 16 | 19.2 | 29 | 31.1 | 43 | 44 | 15 | 20 |
| 32/25 | 16 | 24.2 | 35 | 31.1 | 43 | 44 | 17 | 20 |
| 40/25 | 16 | 24.2 | 35 | 39.0 | 52 | 49 | 18 | 20 |
| 40/32 | 16 | 31.1 | 43 | 39.0 | 52 | 49 | 20 | 21 |
| 50/20 | 16 | 19.2 | 29 | 48.9 | 63 | 55 | 16 | 23 |
| 50/25 | 16 | 24.2 | 34 | 48.9 | 63 | 54 | 17 | 25 |
| 50/32 | 16 | 31.1 | 43 | 48.9 | 63 | 54 | 17 | 23 |
| 50/40 | 16 | 39.0 | 52 | 48.9 | 63 | 54 | 25 | 23 |
| 63/25 | 16 | 24.2 | 35 | 61.9 | 80 | 63 | 18 | 24 |
| 63/32 | 16 | 31.1 | 43 | 61.9 | 80 | 63 | 19 | 26 |
| 63/40 | 16 | 39.0 | 52 | 61.9 | 80 | 63 | 20 | 26 |
| 63/50 | 16 | 48.9 | 63 | 61.9 | 80 | 63 | 24 | 27 |
| 75/63 | 16 | 61.9 | 79 | 73.7 | 90 | 63 | 27 | 29 |
| 90/63 | 16 | 61.9 | 79 | 61.9 | 110 | 85 | 27 | 35 |
| 90/75 | 16 | 73.7 | 90 | 73.7 | 110 | 86 | 32 | 35 |
| 110/63 | 16 | 61.9 | 79 | 108.4 | 130 | 86 | 28 | 41 |
| 110/90 | 16 | 88.6 | 130 | 108.4 | 130 | 85 | 34 | 41 |

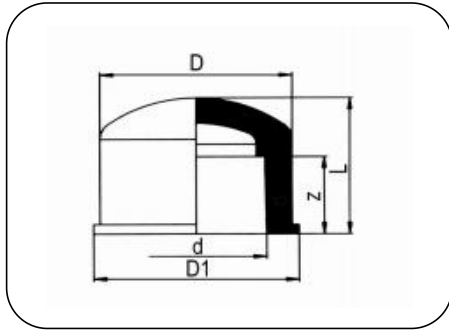

- 管帽 I
- 注塑成型
- 承插焊接
- PVDF 本色
- Eed Cap I
- Injection moulded
- Socket welding
- PVDF natural

| 尺寸 Dimension | 公称压力 PN | d mm | D mm | D1 mm | L mm | z mm |
|-----------------|------------|---------|---------|----------|---------|---------|
| 20 | 16 | 19.2 | 32 | 28 | 27 | 16 |
| 25 | 16 | 24.2 | 37 | 35 | 29 | 17 |
| 32 | 16 | 31.1 | 45 | 42 | 34 | 19 |
| 40 | 16 | 39.0 | 56 | 51 | 38 | 21 |
| 50 | 16 | 48.9 | 68 | 63 | 47 | 24 |
| 63 | 16 | 61.9 | 85 | 80 | 54 | 28 |
| 75 | 16 | 73.7 | 95 | 90 | 60 | 34 |
| 90 | 16 | 88.6 | 116 | 109 | 73 | 36 |
| 110 | 16 | 108.4 | 136 | 129 | 89 | 42 |

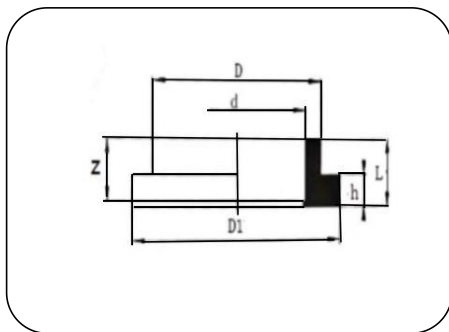

- 法兰转接头 I
- 注塑成型
- 承插焊接
- PVDF 本色
- Stub Flange I
- Injection moulded
- Socket welding
- PVDF natural

| 尺寸 Dimension | 公称压力 PN | d mm | D mm | D1 mm | L mm | h mm | z mm |
|-----------------|------------|---------|---------|----------|---------|---------|---------|
| 20 | 16 | 19.2 | 26 | 44 | 23 | 8 | 15 |
| 25 | 16 | 24.2 | 32 | 57 | 23 | 9 | 17 |
| 32 | 16 | 31.1 | 41 | 68 | 27 | 9 | 19 |
| 40 | 16 | 39.0 | 50 | 77 | 27 | 9 | 19 |
| 50 | 16 | 48.9 | 61 | 87 | 32 | 11 | 25 |
| 63 | 16 | 61.9 | 75 | 100 | 34 | 11 | 27 |
| 75 | 16 | 73.7 | 89 | 118 | 40 | 14 | 31 |
| 90 | 16 | 88.6 | 108 | 124 | 42 | 13 | 36 |
| 110 | 16 | 108.4 | 130 | 148 | 50 | 15 | 43 |

对焊管件

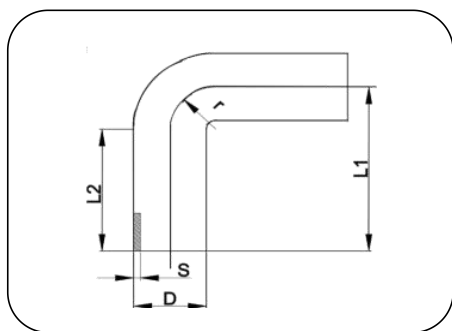

- 90° 弯头 I
- 注塑成型
- 对 焊
- PVDF 本色
- Elbow 90° I
- Injection moulded
- Butt
- PVDF natural

| 尺寸 Dimension | 公称压力 PN | D mm | S mm | L1 mm | L2 mm | r mm |
|-----------------|------------|---------|---------|----------|----------|---------|
| 20 | 16 | 20 | 1.9 | 51 | 31 | 20 |
| 25 | 16 | 25 | 1.9 | 56 | 31 | 25 |
| 32 | 16 | 32 | 2.4 | 64 | 44 | 32 |
| 40 | 16 | 40 | 2.4 | 72 | 47 | 40 |
| 50 | 16 | 50 | 3.0 | 84 | 52 | 50 |
| 63 | 16 | 63 | 3.0 | 95 | 60 | 63 |
| 75 | 16 | 75 | 3.6 | 96 | 57 | 75 |
| 90 | 16 | 90 | 4.3 | 102 | 47 | 90 |
| 110 | 16 | 110 | 5.3 | 138 | 47 | 110 |
| 140 | 16 | 140 | 6.7 | 145 | 55 | 140 |
| 160 | 16 | 160 | 7.7 | 175 | 55 | 160 |
| 225 | 16 | 225 | 10.8 | 232 | 55 | 225 |

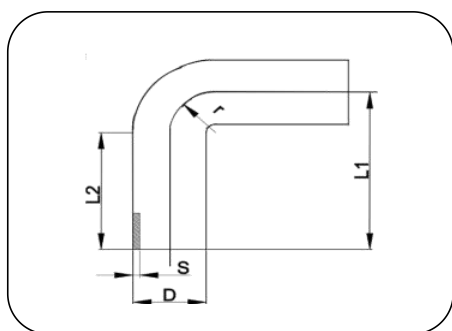

- 90° 弯头 I
- 注塑成型
- 对 焊
- PVDF 本色
- Elbow 90° I
- Injection moulded
- Butt
- PVDF natural

| 尺寸 Dimension | 公称压力 PN | D mm | S mm | L1 mm | L2 mm | r mm |
|-----------------|------------|---------|---------|----------|----------|---------|
| 90 | 10 | 90 | 2.8 | 102 | 47 | 90 |
| 110 | 10 | 110 | 3.4 | 138 | 47 | 110 |
| 140 | 10 | 140 | 4.3 | 145 | 55 | 140 |
| 160 | 10 | 160 | 4.9 | 175 | 53 | 160 |
| 225 | 10 | 225 | 6.9 | 232 | 55 | 225 |
| 280 | 10 | 280 | 8.6 | 283 | 48 | 280 |
| 315 | 10 | 315 | 9.7 | 321 | 48 | 315 |
| 400 | 10 | 400 | 12.3 | 396 | 100 | 400 |

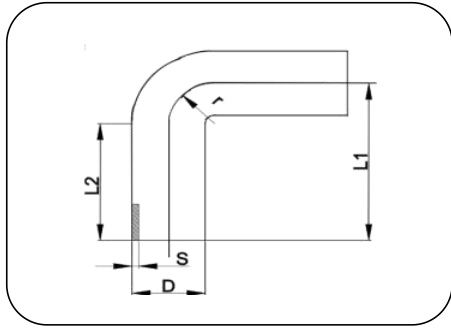

- 90° 弯头 II
- 注塑成型
- 对 焊
- PVDF 本色
- Elbow 90° II
- Injection moulded
- Butt
- PVDF natural

| 尺寸 Dimension | 公称压力 PN | D mm | S mm | L1 mm | L2 mm | r mm |
|-----------------|------------|---------|---------|----------|----------|---------|
| 20 | 16 | 20 | 1.9 | 38 | 23 | 15 |
| 25 | 16 | 25 | 1.9 | 42 | 23 | 19 |
| 32 | 16 | 32 | 2.4 | 46 | 22 | 24 |
| 40 | 16 | 40 | 2.4 | 51 | 21 | 30 |
| 50 | 16 | 50 | 3.0 | 58 | 21 | 37 |
| 63 | 16 | 63 | 3.0 | 66 | 21 | 45 |

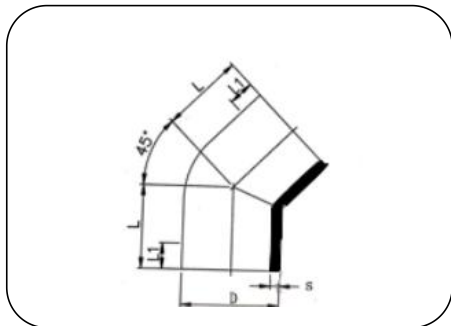

- 45° 弯头 I
- 注塑成型
- 对 焊
- PVDF 本色
- Elbow 45° I
- Injection moulded
- Butt
- PVDF natural

| 尺寸 Dimension | 公称压力 PN | D mm | S mm | L mm | L1 mm |
|-----------------|------------|---------|---------|---------|----------|
| 20 | 16 | 20 | 1.9 | 32 | 25 |
| 25 | 16 | 25 | 1.9 | 34 | 26 |
| 32 | 16 | 32 | 2.4 | 36 | 26 |
| 40 | 16 | 40 | 2.4 | 38 | 28 |
| 50 | 16 | 50 | 3.0 | 42 | 30 |
| 63 | 16 | 63 | 3.0 | 47 | 31 |

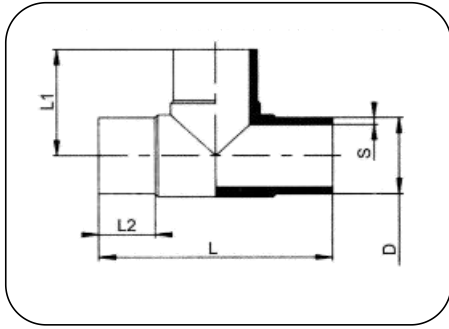

- 三通 I
- 注塑成型
- 对焊
- PVDF 本色
- Tee I
- Injection moulded
- Butt
- PVDF natural

| 尺寸 Dimension | 公称压力 PN | D mm | S mm | L mm | L1 mm | L2 mm |
|-----------------|------------|---------|---------|---------|----------|----------|
| 20 | 16 | 20 | 1.9 | 70 | 35 | 14 |
| 25 | 16 | 25 | 1.9 | 80 | 40 | 14 |
| 32 | 16 | 32 | 2.4 | 89 | 46 | 16 |
| 40 | 16 | 40 | 2.4 | 100 | 50 | 17 |
| 50 | 16 | 50 | 3.0 | 120 | 61 | 22 |
| 63 | 16 | 63 | 3.0 | 148 | 74 | 27 |
| 75 | 16 | 75 | 3.6 | 173 | 117 | 70 |
| 90 | 16 | 90 | 4.3 | 183 | 142 | 78 |
| 110 | 16 | 110 | 5.3 | 219 | 154 | 84 |
| 140 | 16 | 140 | 6.7 | 305 | 155 | 59 |
| 160 | 16 | 160 | 7.7 | 277 | 140 | 45 |
| 225 | 16 | 225 | 10.8 | 455 | 212 | 98 |

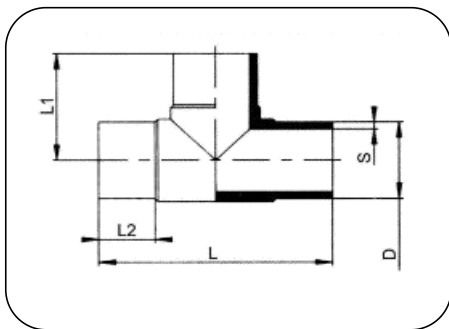

- 三通 II
- 注塑成型
- 对焊
- PVDF 本色
- Tee II
- Injection moulded
- Butt
- PVDF natural

| 尺寸 Dimension | 公称压力 PN | D mm | S mm | L mm | L1 mm | L2 mm |
|-----------------|------------|---------|---------|---------|----------|----------|
| 20 | 16 | 20 | 1.9 | 76 | 38 | 28 |
| 25 | 16 | 25 | 1.9 | 84 | 42 | 29 |
| 32 | 16 | 32 | 2.4 | 93 | 46 | 29 |
| 40 | 16 | 40 | 2.4 | 102 | 50 | 29 |
| 50 | 16 | 50 | 3.0 | 116 | 58 | 29 |
| 63 | 16 | 63 | 3.0 | 132 | 66 | 29 |

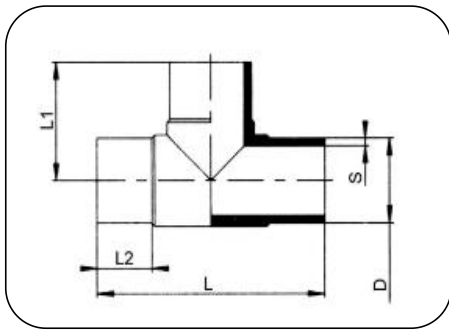

- 三通 I
- Tee I
- 注塑成型
- Injection moulded
- 对焊
- Butt
- PVDF 本色
- PVDF natural

| 尺寸 Dimension | 公称压力 PN | D mm | S mm | L mm | L1 mm | L2 mm |
|-----------------|------------|---------|---------|---------|----------|----------|
| 90 | 10 | 90 | 2.8 | 183 | 142 | 78 |
| 110 | 10 | 110 | 3.4 | 219 | 154 | 84 |
| 140 | 10 | 140 | 4.3 | 305 | 155 | 59 |
| 160 | 10 | 160 | 4.9 | 277 | 140 | 45 |
| 225 | 10 | 225 | 6.9 | 445 | 212 | 98 |
| 280 | 10 | 280 | 8.6 | 512 | 256 | 74 |
| 315 | 10 | 315 | 9.7 | 548 | 274 | 74 |

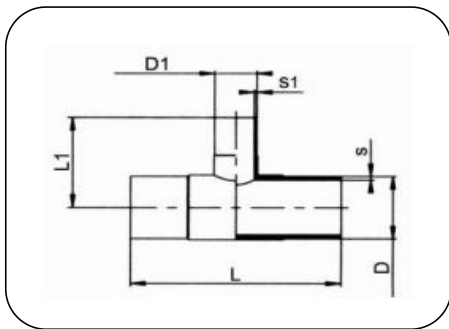

- 异径三通 II
- Tee reduced II
- 注塑成型
- Injection moulded
- 对焊
- Butt
- PVDF 本色
- PVDF natural

| 尺寸 Dimension | 公称压力 PN | D mm | D1 mm | S mm | S1 mm | L mm | L1 mm | L2 mm | L3 mm |
|-----------------|------------|---------|----------|---------|----------|---------|----------|----------|----------|
| 90*63 | 16 | 90 | 63 | 4.3 | 3.0 | 160 | 86 | 26 | 26 |
| 110*20 | 16 | 110 | 20 | 5.3 | 1.9 | 142 | 87 | 25 | 26 |
| 110*32 | 16 | 110 | 32 | 5.3 | 2.4 | 143 | 88 | 25 | 25 |
| 110*40 | 16 | 110 | 40 | 5.3 | 2.4 | 146 | 91 | 25 | 26 |
| 110*50 | 16 | 110 | 50 | 5.3 | 3.0 | 130 | 87 | 25 | 26 |
| 110*63 | 16 | 110 | 63 | 5.3 | 3.0 | 150 | 96 | 30 | 25 |
| 110*75 | 16 | 110 | 75 | 5.3 | 3.6 | 151 | 96 | 30 | 26 |
| 110*90 | 16 | 110 | 90 | 5.3 | 4.3 | 152 | 97 | 31 | 25 |

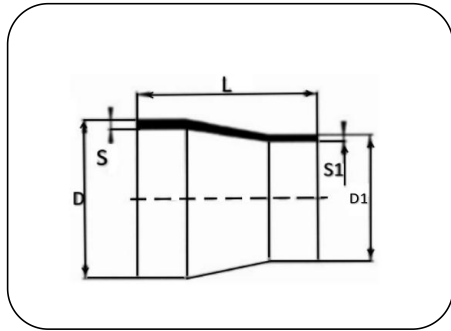

- 同心变径 I ● Reducer concentric I
- 注塑成型或机加工 ● Injection moulded or
Process moulded
- 对 焊 ● Butt
- PVDF 本色 ● PVDF natural

| 尺寸 Dimension | 公称压力 PN | L mm | D mm | D1 mm | S mm | S1 mm |
|-----------------|------------|---------|---------|----------|---------|----------|
| 25/20 | 16 | 50 | 25 | 20 | 1.9 | 1.9 |
| 32/20 | 16 | 50 | 32 | 20 | 2.4 | 1.9 |
| 32/25 | 16 | 50 | 32 | 25 | 2.4 | 1.9 |
| 40/20 | 16 | 58 | 40 | 20 | 2.4 | 1.9 |
| 40/25 | 16 | 55 | 40 | 25 | 2.4 | 1.9 |
| 40/32 | 16 | 55 | 40 | 32 | 2.4 | 2.4 |
| 50/25 | 16 | 60 | 50 | 25 | 3.0 | 1.9 |
| 50/32 | 16 | 60 | 50 | 32 | 3.0 | 2.4 |
| 50/40 | 16 | 60 | 50 | 40 | 3.0 | 2.4 |
| 63/32 | 16 | 65 | 63 | 32 | 3.0 | 2.4 |
| 63/40 | 16 | 65 | 63 | 40 | 3.0 | 2.4 |
| 63/50 | 16 | 65 | 63 | 50 | 3.0 | 3.0 |
| 75/40 | 16 | 68 | 75 | 40 | 3.6 | 2.4 |
| 75/50 | 16 | 65 | 75 | 50 | 3.6 | 3.0 |
| 75/63 | 16 | 65 | 75 | 63 | 3.6 | 3.0 |
| 90/50 | 16 | 75 | 90 | 50 | 4.3 | 3.0 |
| 90/63 | 16 | 75 | 90 | 63 | 4.3 | 3.0 |
| 90/75 | 16 | 75 | 90 | 75 | 4.3 | 3.6 |
| 110/63 | 16 | 90 | 110 | 63 | 5.3 | 3.0 |
| 110/75 | 16 | 90 | 110 | 75 | 5.3 | 3.6 |
| 110/90 | 16 | 90 | 110 | 90 | 5.3 | 4.3 |
| 140/110 | 16 | 110 | 140 | 110 | 6.7 | 5.3 |
| 160/110 | 16 | 120 | 160 | 110 | 7.7 | 5.3 |
| 160/140 | 16 | 120 | 160 | 140 | 7.7 | 6.7 |
| 200/160 | 16 | 145 | 200 | 160 | 9.6 | 7.7 |
| 225/110 | 16 | 160 | 225 | 110 | 10.8 | 5.3 |
| 225/160 | 16 | 160 | 225 | 160 | 10.8 | 7.7 |
| 225/200 | 16 | 160 | 225 | 200 | 10.8 | 9.6 |

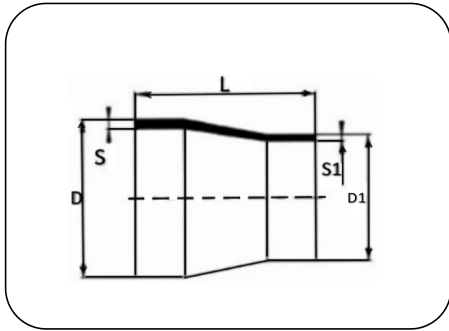

- 同心变径 I
- 注塑成型或机加工
- 对 焊
- PVDF 本色
- Reducer concentric I
- Injection moulded or Process moulded
- Butt
- PVDF natural

| 尺寸 Dimension | 公称压力 PN | L mm | D mm | D1 mm | S mm | S1 mm |
|-----------------|------------|---------|---------|----------|---------|----------|
| 90/63 | 10 | 75 | 90 | 63 | 2.8 | 3.0 |
| 110/63 | 10 | 90 | 110 | 63 | 3.4 | 3.0 |
| 110/90 | 10 | 90 | 110 | 90 | 3.4 | 2.8 |
| 125/110 | 10 | 100 | 125 | 110 | 3.9 | 5.3 |
| 140/110 | 10 | 110 | 140 | 110 | 4.3 | 5.3 |
| 140/125 | 10 | 110 | 140 | 125 | 4.3 | 3.9 |
| 160/110 | 10 | 120 | 160 | 110 | 4.9 | 3.4 |
| 160/140 | 10 | 120 | 160 | 140 | 4.9 | 4.3 |
| 200/160 | 10 | 145 | 200 | 160 | 6.2 | 4.9 |
| 225/110 | 10 | 160 | 225 | 110 | 6.9 | 3.4 |
| 225/160 | 10 | 160 | 225 | 160 | 6.9 | 4.9 |
| 225/200 | 10 | 160 | 225 | 200 | 6.9 | 6.2 |
| 250/225 | 10 | 182 | 250 | 225 | 7.7 | 6.9 |
| 280/225 | 10 | 206 | 280 | 225 | 8.6 | 6.9 |
| 315/225 | 10 | 231 | 315 | 225 | 9.7 | 6.9 |

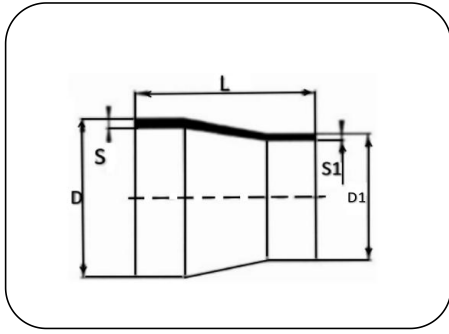

- 同心变径 II
- 注塑成型或机加工
- 对焊
- PVDF 本色
- Reducer concentric II
- Injection moulded or Process moulded
- Butt
- PVDF natural

| 尺寸 Dimension | 公称压力 PN | L mm | D mm | D1 mm | S mm | S1 mm |
|-----------------|------------|---------|---------|----------|---------|----------|
| 25/20 | 16 | 50 | 25 | 20 | 1.9 | 1.9 |
| 32/20 | 16 | 50 | 32 | 20 | 2.4 | 1.9 |
| 32/25 | 16 | 50 | 32 | 25 | 2.4 | 1.9 |
| 40/20 | 16 | 58 | 40 | 20 | 2.4 | 1.9 |
| 40/25 | 16 | 55 | 40 | 25 | 2.4 | 1.9 |
| 40/32 | 16 | 55 | 40 | 32 | 2.4 | 2.4 |
| 50/20 | 16 | 60 | 50 | 25 | 3.0 | 1.9 |
| 50/25 | 16 | 60 | 50 | 25 | 3.0 | 1.9 |
| 50/32 | 16 | 60 | 50 | 32 | 3.0 | 2.4 |
| 50/40 | 16 | 60 | 50 | 40 | 3.0 | 2.4 |
| 63/25 | 16 | 65 | 63 | 25 | 3.0 | 1.9 |
| 63/32 | 16 | 65 | 63 | 32 | 3.0 | 2.4 |
| 63/40 | 16 | 65 | 63 | 40 | 3.0 | 2.4 |
| 63/50 | 16 | 65 | 63 | 50 | 3.0 | 3.0 |
| 75/50 | 16 | 65 | 75 | 50 | 3.6 | 3.0 |
| 75/63 | 16 | 65 | 75 | 63 | 3.6 | 3.0 |
| 90/50 | 16 | 78 | 90 | 50 | 4.3 | 3.0 |
| 90/63 | 16 | 75 | 90 | 63 | 4.3 | 3.0 |
| 110/63 | 16 | 90 | 110 | 63 | 5.3 | 3.0 |
| 110/75 | 16 | 90 | 110 | 75 | 5.3 | 3.6 |
| 110/90 | 16 | 90 | 110 | 90 | 5.3 | 4.3 |

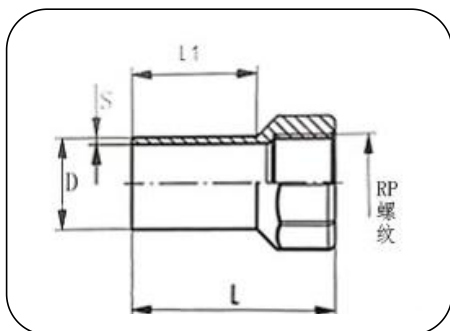

- 内螺纹管接头 I
- 注塑成型或机加工
- 对焊
- PVDF 本色
- Adaptor Female Thread I
- Injection moulded or Process molding
- Butt
- PVDF natural

| 尺寸 Dimension | 公称压力 PN | D mm | S mm | L mm | L1 mm | RP inch |
|-----------------|------------|---------|---------|---------|----------|------------|
| 20 | 16 | 20 | 1.9 | 58 | 37 | 1/2 |

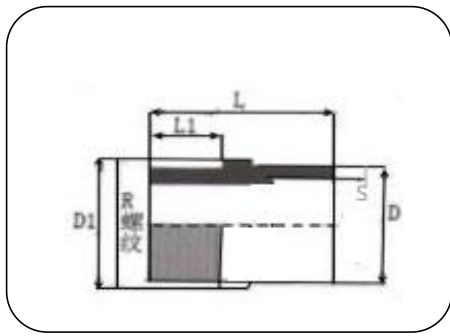

- 外螺纹管接头 I
- 注塑成型或机加工
- 对焊
- PVDF 本色
- Adaptor Male Thread I
- Injection moulded or Process molding
- Butt
- PVDF natural

| 尺寸 Dimension | 公称压力 PN | D mm | S mm | L mm | L1 mm | R inch |
|-----------------|------------|---------|---------|---------|----------|-----------|
| 20 | 16 | 20 | 1.9 | 53 | 26 | 1/2 |
| 25 | 16 | 25 | 1.9 | 55 | 27 | 3/4 |
| 32 | 16 | 32 | 2.4 | 57 | 28 | 1 |

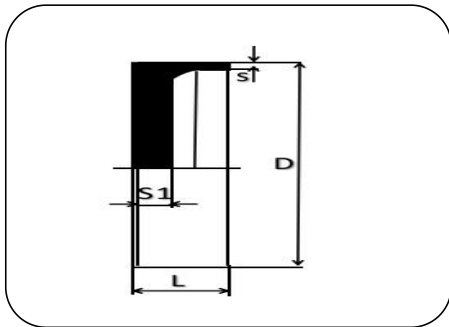

- 管帽 I
- 机加工
- 对焊
- PVDF 本色
- End Cap I
- Machined
- Butt
- PVDF natural

| 尺寸 Dimension | 公称压力 PN | D mm | L mm | S mm | S1 mm |
|-----------------|------------|---------|---------|---------|----------|
| 20 | 16 | 20 | 25 | 1.9 | 5 |
| 25 | 16 | 25 | 25 | 1.9 | 5 |
| 32 | 16 | 32 | 25 | 2.4 | 5 |
| 40 | 16 | 40 | 25 | 2.4 | 7 |
| 50 | 16 | 50 | 25 | 3.0 | 7 |
| 63 | 16 | 63 | 25 | 3.0 | 9 |
| 75 | 16 | 75 | 29 | 3.6 | 10 |
| 90 | 16 | 90 | 30 | 4.3 | 10 |
| 110 | 16 | 110 | 30 | 5.3 | 10 |
| 160 | 16 | 160 | 60 | 7.7 | 12 |
| 225 | 16 | 225 | 100 | 10.8 | 15 |

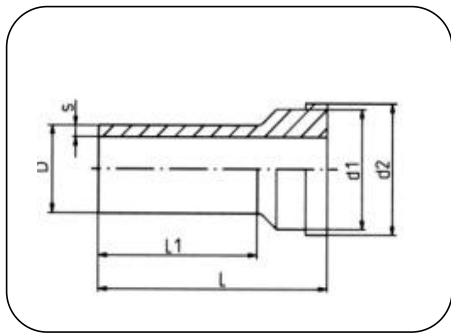

- 活接端 I
- 注塑成型
- 对焊
- PVDF 本色
- Union end I
- Injection moulded
- Butt
- PVDF natural

| 尺寸 Dimension | 公称压力 PN | D mm | S mm | L mm | L1 mm | d1 mm | d2 mm |
|-----------------|------------|---------|---------|---------|----------|----------|----------|
| 20 | 16 | 20 | 1.9 | 52 | 37 | 23 | 29 |
| 25 | 16 | 25 | 1.9 | 56 | 38 | 31 | 38 |
| 32 | 16 | 32 | 2.4 | 59 | 40 | 37 | 44 |
| 40 | 16 | 40 | 2.4 | 63 | 41 | 47 | 55 |
| 50 | 16 | 50 | 3.0 | 66 | 44 | 55 | 62 |
| 63 | 16 | 63 | 3.0 | 69 | 45 | 69 | 78 |

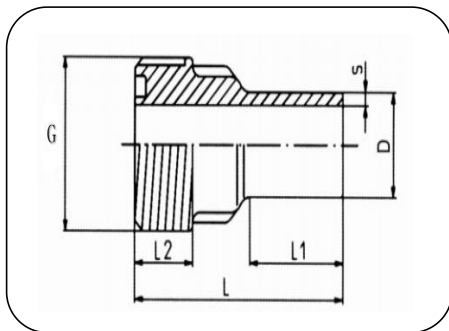

- 活接套筒 I
- G 螺纹
- 注塑成型
- 对焊
- PVDF 本色
- Union bush I
- G thread
- Injection moulded
- Butt
- PVDF natural

| 尺寸 Dimension | 公称压力 PN | D mm | S mm | L mm | L1 mm | L2 mm | G inch |
|-----------------|------------|---------|---------|---------|----------|----------|-----------|
| 20 | 16 | 20 | 1.9 | 52 | 25 | 13 | 1 |
| 25 | 16 | 25 | 1.9 | 57 | 26 | 14 | 1 1/4 |
| 32 | 16 | 32 | 2.4 | 60 | 25 | 14 | 1 1/2 |
| 40 | 16 | 40 | 2.4 | 60 | 24 | 14 | 2 |
| 50 | 16 | 50 | 3.0 | 65 | 24 | 19 | 2 1/4 |
| 63 | 16 | 63 | 3.0 | 68 | 25 | 19 | 2 3/4 |

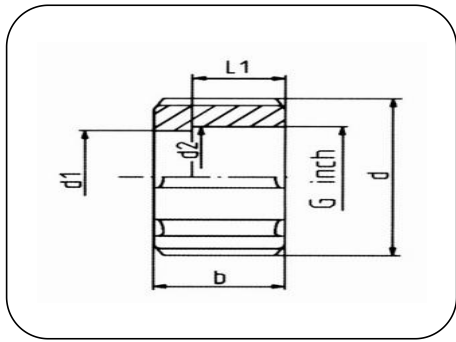

- 活接螺母 I
- G 螺纹
- 注塑成型
- PVDF 本色
- Union nut I
- G thread
- Injection moulded
- PVDF natural

| 尺寸 Dimension | 公称压力 PN | D mm | d1 mm | d2 mm | L1 mm | L mm | G inch |
|-----------------|------------|---------|----------|----------|----------|---------|-----------|
| 20 | 16 | 42 | 22 | 30 | 17 | 22 | 1 |
| 25 | 16 | 53 | 31 | 39 | 19 | 24 | 1 1/4 |
| 32 | 16 | 61 | 38 | 45 | 19 | 26 | 1 1/2 |
| 40 | 16 | 72 | 48 | 57 | 22 | 28 | 2 |
| 50 | 16 | 82 | 54 | 62 | 25 | 33 | 2 1/4 |
| 63 | 16 | 100 | 70 | 78 | 27 | 35 | 2 3/4 |

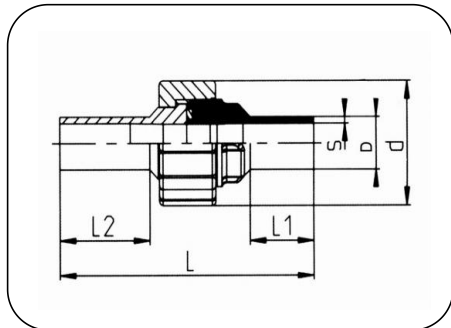

- 活接 I
- FPM-密封
- 注塑成型
- 对焊
- PVDF 本色
- Union Type I
- FPM-sealing
- Injection moulded
- Butt
- PVDF natural

| 尺寸 Dimension | 公称压力 PN | D mm | d mm | S mm | L mm | L1 mm | L2 mm |
|-----------------|------------|---------|---------|---------|---------|----------|----------|
| 20 | 16 | 20 | 42 | 1.9 | 106 | 25 | 37 |
| 25 | 16 | 25 | 52 | 1.9 | 114 | 26 | 38 |
| 32 | 16 | 32 | 60 | 2.4 | 120 | 25 | 40 |
| 40 | 16 | 40 | 73 | 2.4 | 127 | 24 | 41 |
| 50 | 16 | 50 | 80 | 3.0 | 133 | 24 | 44 |
| 63 | 16 | 63 | 100 | 3.0 | 138 | 25 | 45 |

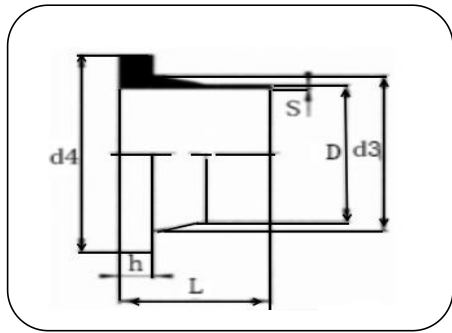

- 法兰转接头 I
- 注塑成型
- 对 焊
- PVDF 本色
- Stub Flange I
- Injection moulded
- Butt
- PVDF natural

| 尺寸 Dimension | 公称压力 PN | D mm | d3 mm | d4 mm | S mm | L mm | h mm |
|-----------------|------------|---------|----------|----------|---------|---------|---------|
| 20 | 16 | 20 | 26 | 44 | 1.9 | 49 | 5 |
| 25 | 16 | 25 | 31 | 57 | 1.9 | 49 | 6 |
| 32 | 16 | 32 | 38 | 67 | 2.4 | 50 | 7 |
| 40 | 16 | 40 | 48 | 77 | 2.4 | 49 | 8 |
| 50 | 16 | 50 | 58 | 85 | 3.0 | 49 | 9 |
| 63 | 16 | 63 | 72 | 100 | 3.0 | 49 | 10 |
| 75 | 16 | 75 | 86 | 120 | 3.6 | 57 | 10 |
| 90 | 16 | 90 | 100 | 135 | 4.3 | 78 | 11 |
| 110 | 16 | 110 | 119 | 156 | 5.3 | 78 | 13 |
| 140 | 16 | 140 | 149 | 184 | 6.7 | 78 | 17 |
| 160 | 16 | 160 | 168 | 208 | 7.7 | 78 | 17 |
| 225 | 16 | 225 | 226 | 260 | 10.8 | 98 | 19 |

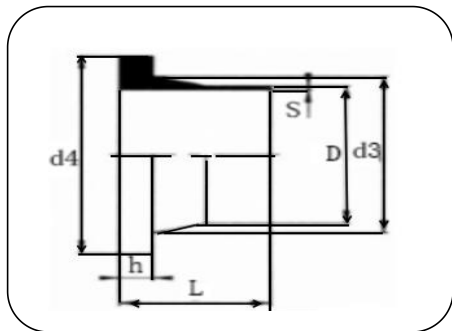

- 法兰转接头 I
- 注塑成型
- 对 焊
- PVDF 本色
- Stub Flange I
- Injection moulded
- Butt
- PVDF natural

| 尺寸 Dimension | 公称压力 PN | D mm | d3 mm | d4 mm | S mm | L mm | h mm |
|-----------------|------------|---------|----------|----------|---------|---------|---------|
| 90 | 10 | 90 | 100 | 135 | 2.8 | 78 | 11 |
| 110 | 10 | 110 | 119 | 156 | 3.4 | 78 | 13 |
| 140 | 10 | 140 | 149 | 184 | 4.3 | 78 | 17 |
| 160 | 10 | 160 | 168 | 208 | 4.9 | 78 | 17 |
| 225 | 10 | 225 | 226 | 260 | 6.9 | 98 | 19 |
| 280 | 10 | 280 | 291 | 320 | 8.6 | 120 | 22 |
| 315 | 10 | 315 | 335 | 370 | 9.7 | 120 | 22 |

球 阀

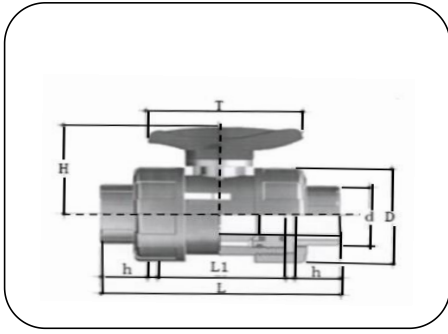

- 球 阀
- FPM 密封
- 注塑成型
- 承插连接
- PVDF 本色
- Ball Valve
- FPM-sealing
- Injecrion moulded
- Socket welding
- PVDF natural

| 尺寸 Dimension | 公称压力 PN | d mm | D mm | H mm | h mm | L mm | L1 mm | T mm |
|-----------------|------------|---------|---------|---------|---------|---------|----------|---------|
| 20 | 10 | 19.2 | 48 | 72 | 20 | 108 | 65 | 72 |
| 25 | 10 | 24.2 | 59 | 59 | 23 | 119 | 70 | 72 |
| 32 | 10 | 31.1 | 67 | 70 | 26 | 132 | 79 | 89 |
| 40 | 10 | 39.0 | 80 | 85 | 29 | 148 | 88 | 108 |
| 50 | 10 | 48.9 | 98 | 99 | 32 | 160 | 92 | 122 |
| 63 | 10 | 61.9 | 119 | 115 | 34 | 179 | 109 | 133 |

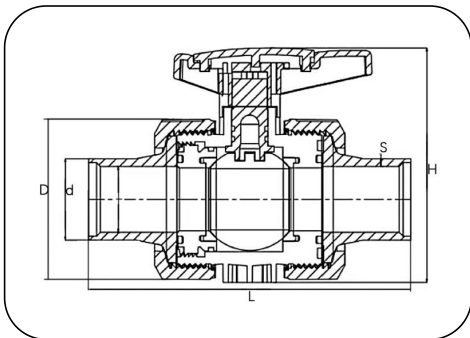

- 球 阀
- FPM 密封
- 注塑成型
- 对 焊
- PVDF 本色
- Ball Valve
- FPM-sealing
- Injection moulded
- Butt
- PVDF natural

| 尺寸 Dimension | 公称压力 PN | D mm | d mm | H mm | S mm | L mm |
|-----------------|------------|---------|---------|---------|---------|---------|
| 20 | 10 | 51 | 20 | 80 | 1.9 | 171 |
| 25 | 10 | 60 | 50 | 100 | 1.9 | 177 |
| 32 | 10 | 69 | 32 | 107 | 2.4 | 193 |
| 40 | 10 | 85 | 40 | 134 | 2.4 | 209 |
| 50 | 10 | 100 | 50 | 145 | 3.0 | 221 |
| 63 | 10 | 124 | 63 | 181 | 3.0 | 249 |

法兰系列

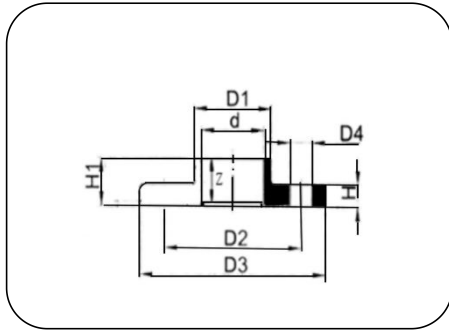

- 整体法兰 I
- 注塑成型
- 承插焊接
- PVDF 本色
- Integral flangr I
- Injection moulded
- Socket welding
- PVDF natural

| 尺寸 Dimension | 公称压力 PN | 产品编码 Code | d mm | D1 mm | D2 mm | D3 mm | D4 mm | H mm | H1 mm | z mm |
|-----------------|------------|--------------|---------|----------|----------|----------|----------|---------|----------|---------|
| 20 | 16 | 11011402001 | 19.2 | 29 | 64 | 93 | 13 | 13 | 20 | 16 |
| 25 | 16 | 11011402501 | 24.2 | 35 | 73 | 103 | 13 | 17 | 24 | 19 |
| 32 | 16 | 11011403201 | 31.1 | 42 | 83 | 103 | 13 | 17 | 22 | 19 |
| 40 | 16 | 11011404001 | 39.0 | 52 | 94 | 137 | 13 | 20 | 30 | 25 |
| 50 | 16 | 11011405001 | 48.9 | 65 | 107 | 147 | 17 | 20 | 31 | 23 |
| 63 | 16 | 11011406301 | 61.9 | 82 | 122 | 162 | 17 | 25 | 38 | 28 |
| 75 | 16 | 11011407501 | 73.7 | 97 | 142 | 182 | 17 | 24 | 42 | 30 |
| 90 | 16 | 11011409001 | 88.6 | 102 | 158 | 198 | 17 | 27 | 49 | 40 |
| 110 | 16 | 11011411001 | 108.4 | 132 | 177 | 217 | 17 | 28 | 60 | 50 |

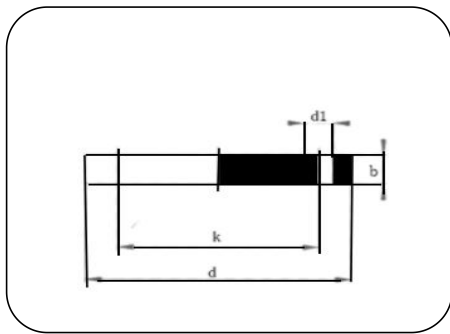

- 无钢芯盲法兰 I
- 注塑成型/按 PN16 钻孔
- 法兰连接
- PVDF 本色
- Blind Flange no steel insert I
- Machinde/drelled PN16
- Flange connertion
- PVDF natural

| 尺寸 Dimension | 公称压力 PN | d mm | d1 mm | b mm | k mm |
|-----------------|------------|---------|----------|---------|---------|
| 20 | 16 | 95 | 14 | 12 | 65 |
| 25 | 16 | 105 | 14 | 15 | 75 |
| 32 | 16 | 115 | 14 | 18 | 85 |
| 40 | 16 | 140 | 18 | 18 | 100 |
| 50 | 16 | 150 | 18 | 21 | 110 |
| 63 | 16 | 165 | 18 | 25 | 125 |
| 75 | 16 | 185 | 18 | 26 | 145 |
| 90 | 16 | 200 | 18 | 26 | 160 |
| 110 | 16 | 220 | 18 | 27 | 180 |

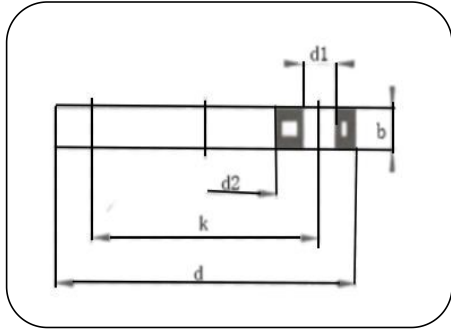

- 法兰环 I
- 钢芯/用于法兰转接头
- 注塑成型+按 PN10 钻孔
- 法兰连接
- PP-H 灰色/黑色
- Backing ring I
- Steel insert/for stuib flangg
- Inj. moulded+drilled PN10
- Flange connection
- PP-H grey or black

| 尺寸 Dimension | 公称压力 PN | d mm | d1 mm | d2 mm | b mm | k mm |
|-----------------|------------|---------|----------|----------|---------|---------|
| 20 | 10 | 95 | 14 | 28 | 13 | 65 |
| 25 | 10 | 105 | 14 | 34 | 15 | 75 |
| 32 | 10 | 115 | 14 | 42 | 17 | 85 |
| 40 | 10 | 140 | 18 | 51 | 18 | 100 |
| 50 | 10 | 150 | 18 | 62 | 19 | 110 |
| 63 | 10 | 165 | 18 | 78 | 19 | 125 |
| 75 | 10 | 185 | 18 | 92 | 19 | 145 |
| 90 | 10 | 200 | 18 | 110 | 20 | 160 |
| 110 | 10 | 220 | 18 | 133 | 20 | 180 |
| 140 | 10 | 249 | 18 | 167 | 24 | 209 |
| 160 | 10 | 285 | 22 | 190 | 24 | 241 |
| 225 | 10 | 340 | 22 | 250 | 24 | 296 |
| 250 | 10 | 395 | 22 | 277 | 30 | 350 |
| 280 | 10 | 395 | 22 | 310 | 30 | 350 |
| 315 | 10 | 445 | 22 | 348 | 32 | 400 |
| 355 | 10 | 515 | 23 | 388 | 32 | 460 |
| 400 | 10 | 574 | 26 | 442 | 40 | 515 |

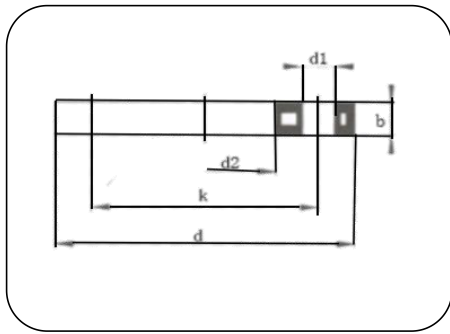

- 法兰环 II
- 钢芯/用于法兰转接头
- 注塑成型+按 PN10/16 钻孔
- 法兰连接
- PP-H 灰色/黑色
- Backing ring II
- Steel insert/for stub flangg
- Inj.moulded+drilled PN10/16
- Flange connection
- PP-H grey or black

| 尺寸 Dimension | 公称压力 PN | d mm | d1 mm | d2 mm | b mm | k mm |
|-----------------|------------|---------|----------|----------|---------|---------|
| 20 | 10 | 95 | 14 | 28 | 11 | 65 |
| 25 | 10 | 105 | 14 | 34 | 15 | 75 |
| 32 | 10 | 115 | 14 | 42 | 15 | 85 |
| 40 | 10 | 140 | 18 | 51 | 15 | 100 |
| 50 | 10 | 150 | 18 | 62 | 17 | 110 |
| 63 | 10 | 165 | 18 | 78 | 17 | 125 |
| 75 | 10 | 185 | 18 | 92 | 17 | 145 |
| 90 | 10 | 200 | 18 | 110 | 19 | 160 |
| 110 | 10 | 220 | 18 | 133 | 19 | 180 |
| 140 | 10 | 249 | 18 | 167 | 23 | 209 |

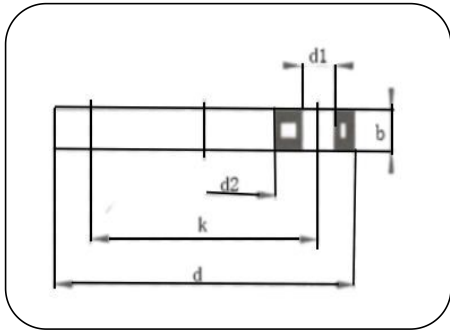

- 法兰环（日标） I
- Backing ring (JIS) I
- 钢芯/用于法兰转接头
- Steel insert/for stub flangg
- 注塑成型+按 PN10 钻孔
- Inj. moulded+drilled PN10
- 法兰连接
- Flange connection
- PP-H 灰色/黑色
- PP-H grey or black

| 尺寸 Dimension | 公称压力 PN | d mm | d1 mm | d2 mm | b mm | k mm |
|-----------------|------------|---------|----------|----------|---------|---------|
| 32 | 10 | 125 | 19 | 42 | 14 | 90 |
| 50 | 10 | 140 | 19 | 62 | 16 | 105 |
| 63 | 10 | 159 | 19 | 78 | 16 | 120 |
| 75 | 10 | 175 | 19 | 92 | 16 | 139 |